

Automatic monitoring, control and data acquisition system of “Prometei” facility

Yu.I.Vinogradov, A.V.Kuryakin, V.S.Aryutkin, S.K.Grishechkin, B.S.Lebedev,
R.K.Musyaiev, V.V.Travkin, S.B.Filchagin, A.A.Yukhimchuk

Russian Federal Nuclear Center-
All-Russia Scientific Research Institute of Experimental Physics (RFNC-VNIIEF),
607190 Sarov, Nizhny Novgorod Region, Russia

Abstract

There is presented a description of the automatic monitoring, control and data acquisition system created in VNIIEF to study into the phenomena of tritium accumulation and transmission by metals and structural materials of the universal facility “Prometei”. The facility enables studying the phenomenon of tritium “superpermeability” through metal membranes, phenomena of tritium accumulation and transmission by structural materials, search and investigation of protective coverings that enhance safety of tritium-containing gas media use.

Introduction

In RFNC-VNIIEF a facility is created to study into the phenomena of tritium accumulation and transmission by metals and structural materials – “Prometei” facility. It consists of two integrated research systems to solve two scientific tasks. The first task consists in studying the phenomenon of tritium “superpermeability” through metal membranes. The second one is to study into tritium accumulation and transmission by structural materials, and to search for and to investigate protective coverings enhancing safety of tritium-containing gas media use. Detailed description of the gas circuit and the facility equipment is presented in work /1/, the facility block-diagram is shown in Fig.1.

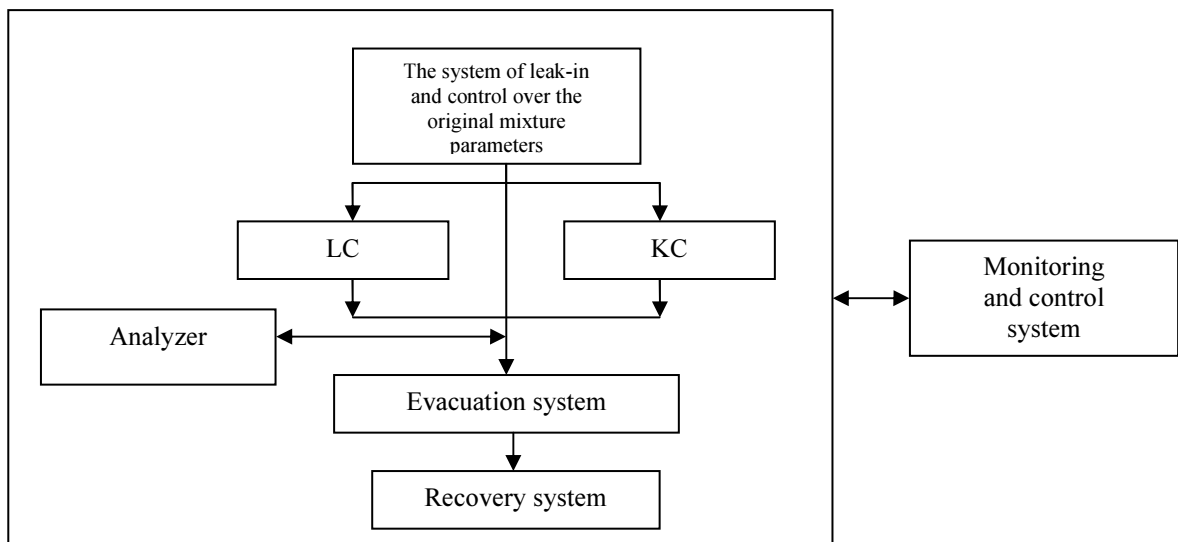

Fig.1. Block-diagram of “Prometei” facility

The facility consists of the following main units:

- the cell to study superpermeability phenomena - LC (Livshitz's cell), which should provide for studies into the phenomenon of superpermeability on cylindrical membranes of relatively large area along with investigation and selection of protective coverings for metals and structural materials (SM) on thin-plate membranes;
- the cell to study into metal and SM protective coverings – KC (Kurdyumov's cell), which should provide for creation of a concentration meander and a possibility to investigate the protective coverings under epithermal particles influence;
- systems of vacuum evacuation, mixed gas preparation and injection, gas mixture analysis, tritium utilization, radiation safety.

Taking into account variety of production equipment incorporated in the facility, complexity of experimental techniques, number of controlled technological and physical parameters, necessity to ensure personnel and environmental safety, it has been decided to develop highly automated monitoring, control and data acquisition system (MCS), the essential part of which is the system of tritium volumetric activity monitoring in gas communications and the facility working zone. MCS development was based upon the experience gained in the creation of the automatic monitoring system of the gas complex used in experiments on muon-catalyzed fusion /2/.

Structure and hardware composition of the facility monitoring and control system

Structure of the monitoring and control system of the facility was defined by its hardware composition and functional destination. A block-diagram of MCS shown in Fig. 3.2 gives an idea of its functions and relations with units and subsystems of the facility. MCS is based upon personal computers PC_1 and PC_2.

Main control computer PC_1 provides for control over evacuation systems, leak-in and recovery systems; preparation and performance of experiments with research cells KC and LC. It also serves to save and represent all technological and physical parameters recorded during preparation and performance of experiments. Data of gas mixture analysis and data of radiation monitoring for tritium come from the second computer PC_2 via RS-232 net in a real-time mode.

The second computer PC_2 ensures gas mixture analysis with the use of mass-spectrometer QMS-200 and operation of the RM system for tritium. Mass-spectrometric and radiation monitoring data can be transmitted over sequential exchange channel to the main control computer, and radiation monitoring data are transferred through Ethernet to the remote computer PC_3 located in the radiation monitoring control room.

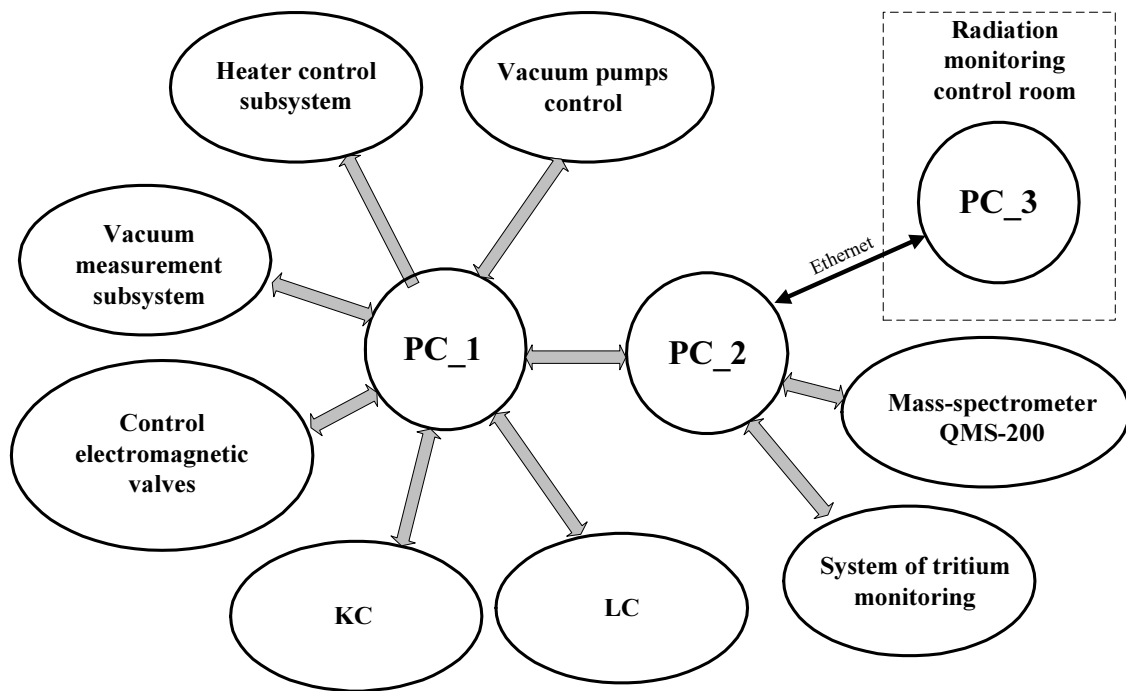

Fig.2. Block - diagram of MCS

Monitoring and control system of the facility PROMETEI incorporates various measuring and control systems:

- 12 electron power controllers for heaters of sources and absorbers;
- 12 thermocouples of chromel/alumel and chromel/copel type to measure temperature of sources and absorbers;
- electron power controller for a heater of the research cell KC;
- thermocouple to measure temperature of the studied KC cell membrane;
- power amplifier with up to 3A output current to form meander on the atomizer of the research cell KC;
- three controlled voltage sources (output voltage up to 50 V, current to 50 A) for atomizer of the research cell LC;
- two pyrometric temperature sensors for the research cell LC;
- 8 Balzers vacuum gauges;
- 2 vacuum lamp transducers PMT-4;
- control unit for 6 electromagnetic valves;
- Balzers quadruple mass-spectrometer QMS-200 for a gas mixture analysis;
- five detector units based upon 1l flow-type ionization chambers;
- detector unit based on a 10l diffusion ionization chamber.

During the experiments MCS hardware is affected by electromagnetic emanation that appears at vacuum pumps, electromagnetic valves, furnace heaters, research cell atomizers etc. turning on/off and operation. That is why in the course of MCS developing particular attention was paid to providing noise-killing features for measuring and control channels, and galvanic insulation of input and output circuits.

ICP DAS modules I-7000 have been chosen for analog/discrete monitoring and control. Many hardware characteristics of these modules are compatible with the products of another manufactures (ADAM, NUDAM, series 6B Analog Devices), however they offer a number of advantages, which ensure high reliability and safety of the automation system:

- they have a watchdog timer, which automatically restarts the module if it's "hanging";

- they have a software watchdog timer, watching over the control computer state. If the computer is “hanging” or communications are broken, this timer sets all outputs of the module into preset states provided for the appropriate case;
- they allow any module “hot”, i.e. without system turning off, substitution.

Automated monitoring and control system is designed as a distributed network, consisting of 3 computers and a set of network modules, interconnected using RS-232 and RS-485 standards [3]. To get data from the sensors and to monitor control units, the following smart devices are used: remote analog and discrete input/output modules I-7000 (produced by ICP DAS firm) with interface RS-485 and data exchange rate to 115200 baud; vacuum gauge controller TPG-256 (Balzers Instruments Company) with interface RS-232 and data exchange rate to 19200 baud, radiation monitoring measuring units (RMMU) with interface RS-232 and data exchange rate to 9600 baud, as well as ISA discrete I/O adapter DIO-144 and asynchronous line adapter RS-232/RS-485 of C-134 type.

In Fig.3 there is presented a network layout of MCS, in which all smart devices are indicated with connection type and exchange rate specification. To connect devices with different interfaces and exchange rates to PC_1 computer (modules of I-7000 series, TPG-256 controllers) a smart, addressable interface converter is used based on I-7188 controller (Processor AMD188/40 MHz, SRAM 256 kb, Flash-disk 512 kb, DOS-compatible operating system), having 4 serial input/output ports. Controllers TPG-256 are connected to ports COM1, COM3 (RS-232) and from the standpoint of RS-485 network have their own virtual addresses. The I-7000 modules are connected to COM2 port (RS-485). COM4 port (RS-232) is used to provide output to the control computer.

Two-channel measuring units for radiation situation control are connected to PC_2 computer through RS-485 port of C-134 adapter. Data exchange between computers PC_1 and PC_2 is implemented via RS-232 channel.

MCS can be subdivided into the following subsystems:

- furnace control subsystem;
- vacuum measurement subsystem;
- gas mixture preparation subsystem;
- KC cell subsystem;
- LC cell subsystem;
- radiation monitoring subsystem.

It should be mentioned that division onto subsystems is conventional, as all of the subsystems need to be involved into experiment preparation and performance. Besides, some of the subsystem resources are common, e.g. different inputs of multichannel ADCs I-7018 are employed by different subsystems. The above subdivision is associated with the logic of operation.

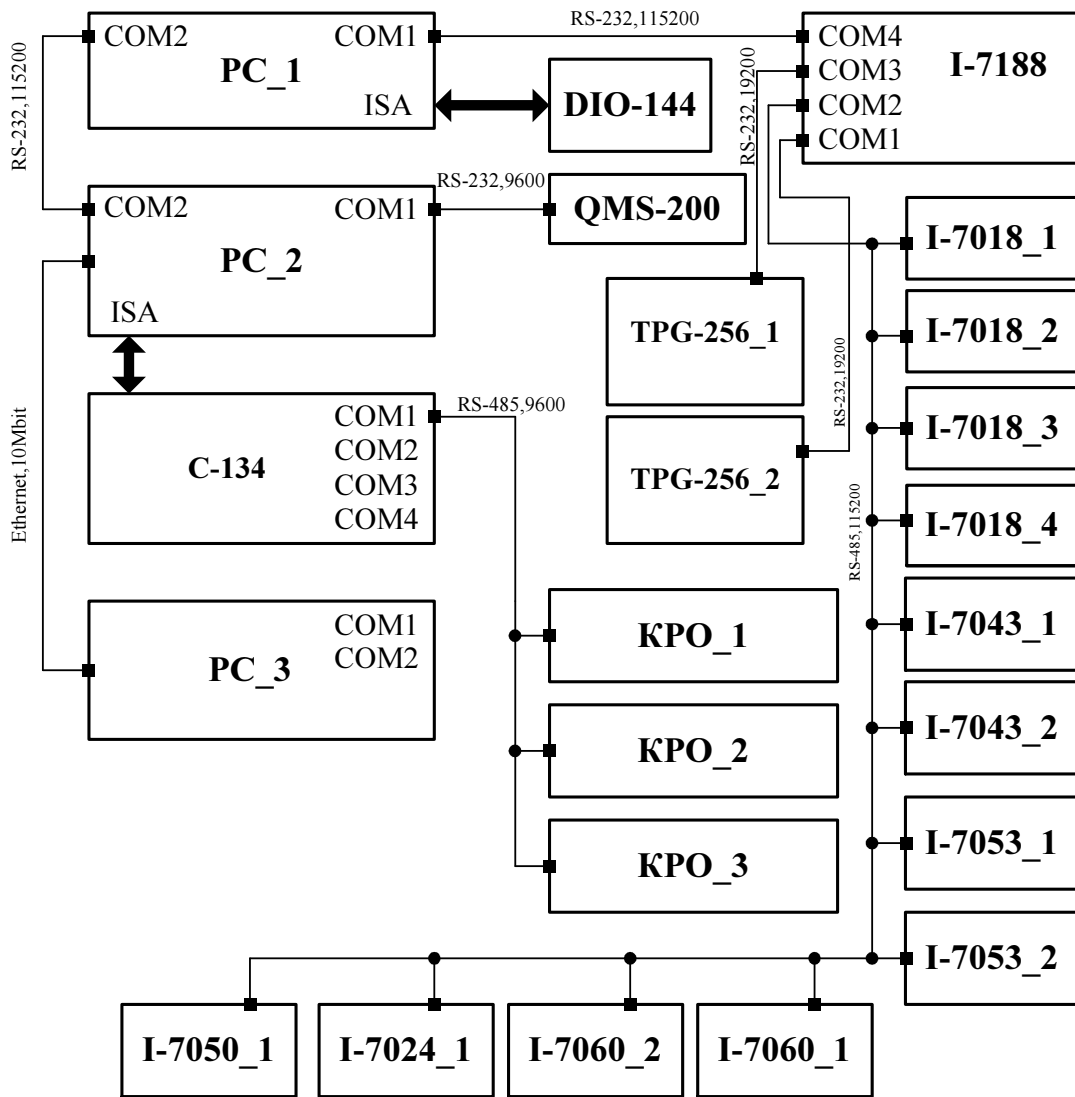

Fig.3. MCS net layout

MCS software

MCS software of PROMEREI facility has been developed using the package CRW-DAQ, which presents a powerful multi-window medium for the development of measuring systems, data control and processing systems. Kernel of the software package CRW_RUN.EXE is run in DOS or DOS session under Windows95/98 on all three MCS computers. Specific program for each computer is defined by a loadable configuration file that is similar to .ini file of the Windows operating system.

Graphic interface for the facility control has been implemented as active mimic panels. The main mimic panel corresponds to the gas circuit of the facility and incorporates elements displaying the state of the facility elements and control units. Measured parameters are presented as texts and graphs in a real time mode. Fig.4 shows general view of the program graphic interface on the main computer PC_1.

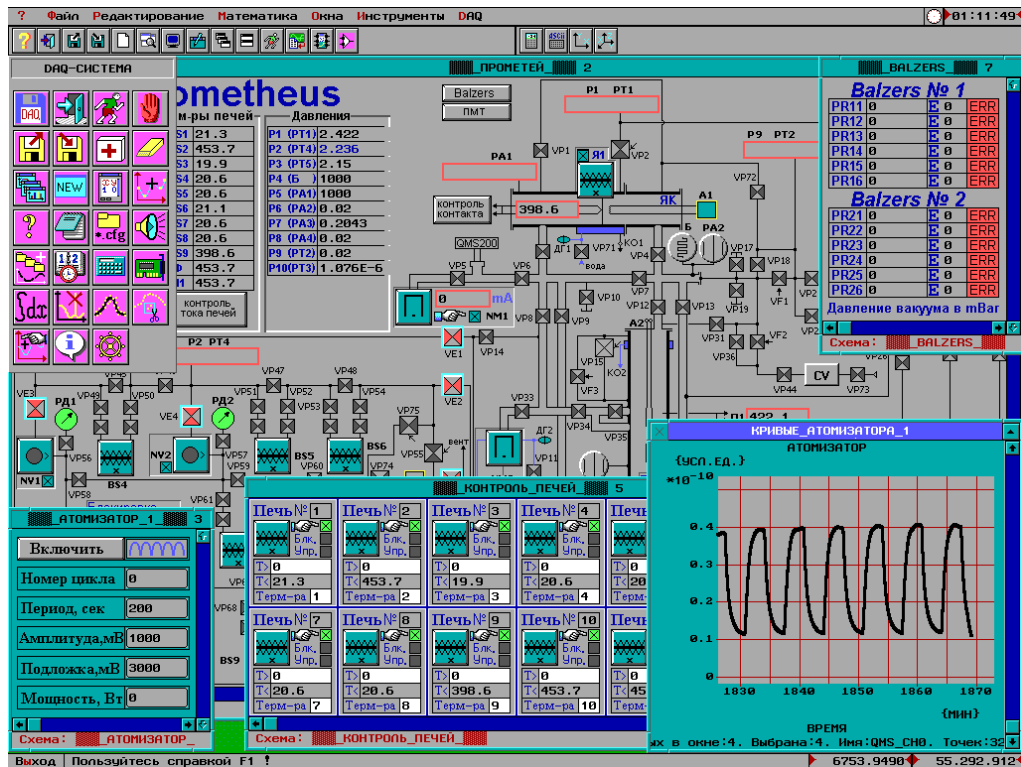

Fig.4 General view of the program graphic interface

Heater control subsystem

The subsystem is composed of 12 automatic channels to control heaters of the hydrogen isotopes generator, absorbers and filters of the mixed gas preparation system. Every channel provides measuring of the furnace temperature, control of the heating temperature, temperature stabilization, control of the power supply circuit break and blocking of the heater's power supply in an emergency.

Temperature of furnaces is measured by chromel-alumel type thermocouples; thermo electromotive force is registered by multichannel analog input I-7018. Heating temperature of furnaces is controlled by means of semester power controllers (maximum output power up to 1 kW) controlled by a logic signal.

The power is regulated by a broad-pulse modulation technique with a 2-5s period. Heated objects are rather massive, therefore oscillations related to the power switch on and off are integrated and do not appear at the observed object temperature. Power controllers are operated by computer through multichannel discrete I/O modules I-7043; temperature is stabilized accurate to $\pm 1\text{ C}^{\circ}$. If computer fails to control, the watchdog timer of the module I-7043 switches the power controller off.

The power regulator actuates the sensor of load current, the current presence in the circuit is detected through the sensor's pulses recording by the discrete input module I-7053. If necessary, for example, on the semistor short circuit, the load can be disconnected by a relay blocking scheme, controlled through discrete output modules of I-7043 type.

Vacuum measurement subsystem

Three thermometric vacuum lamps ПИМТ-4М and 8 Balzers vacuum gauges IKR261, TPR260 are used to control vacuum. Output voltage of ПИМТ-4М lamps' thermotransducers is measured with a multichannel analog input module I-7018, vacuum pressure is calculated using calibration presented in the lamp-attached documentation. Vacuum gauges are activated through two 6-channel controllers TPG-256, operation of controllers and pressure digital data acquisition is accomplished through ports RS-232.

Mixed gas preparation subsystem

Mixed gas preparation system serves to prepare vacuum and hydrogen isotopes based gas mixtures needed for measurements with KC and LC cells. This MCS subsystem makes it possible to:

- produce (by heating the sources) mixed gases of required composition and pressure;
- measure and represent the state of the facility's valves;
- control electromagnetic valves and show their state;
- control magnetodischarch and forevacuum pumps;
- control and display the state of water pressure gauges, limit switches of manometers, etc;
- block valves depending on radiation situation, state of valves, etc.

Subsystem of KC cell

KC cell designed to investigate protective coverings and structural materials is divided into two parts by a membrane, which can be heated up to 1000 K. To the input side the working pressure of hydrogen isotopes is applied within the limits from $2 \cdot 10^{-7}$ to 1 Pa, the output side of the membrane is continuously vacuumed by the pump, penetrating hydrogen isotopes flux is measured by the mass-spectrometer. To bring hydrogen isotopes molecules into atomic state in the cell input portion an atomizer is installed (heater) /1/.

The subsystem provides heating of the membrane, measurement and stabilization of its temperature, pressure measurement at the input and output side of the cell and control over the atomizer. In particular, meander of the atomic hydrogen isotopes non-equilibrium concentration can be created at the input side of the cell. Partial pressure of hydrogen isotopes diffused through membrane can be recorded. Partial pressure of hydrogen isotopes is measured with a quadruple mass-spectrometer QMS-200 connected to computer PC_2 through port RS-232. Data from computer PC_2 are transmitted to the main control computer PC_1 over the network RS-232.

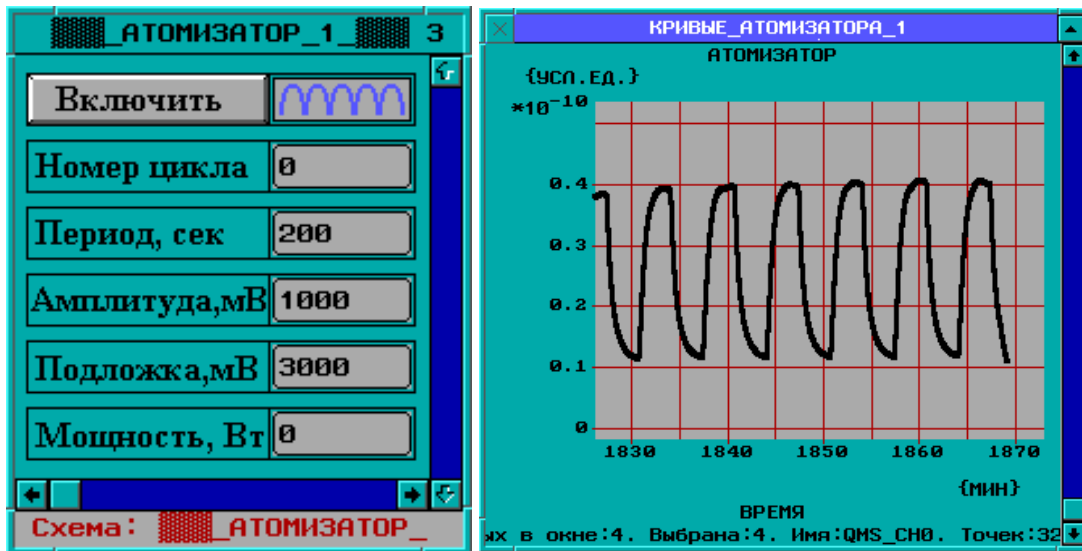

Fig.5 Window for setting meander parameters and the response-function measured by mass-spectrometer

Subsystem of LC cell

LC cell designed to study into the phenomena of hydrogen isotopes superpermeability through metal membranes, includes a cylindrical membrane to be investigated, atomizer, recycle system, pressures and temperature gauges. The vertical cylindrical membrane divides the cell into input and output sides. Through the input side (the cylinder internal volume) continuous pumping of hydrogen isotopes flux is arranged. Inside the membrane an atomizer is located, which presents a set of tantalum plates [1].

The subsystem allows independent adjustment and control of currents through 3 groups of tantalum plates over the range 0 - 50 A at the output power to 2.5kW. Currents are set by controlled power units; 4-channel analog output module I-7024 (14-digit DAC) is used for the outer power supply. To control currents, the multichannel analog input module I-7018 is employed. Membrane temperature is measured at no less than two points by pyrometric gauges placed in special windows. Gas pressure is registered by gauges with appropriate measurement ranges.

Radiation monitoring subsystem

In the Prometei facility design a special attention was given to radiation safety at tritium handling. To ensure safe operation of the facility the principles of physical protection are laid down in its gas system design and a system of radiation monitoring for tritium is provided.

The radiation monitoring system provides tritium volumetric activity monitoring within the facility gas system as well as the control over tritium volumetric activity in the working zone air and both light and audio signaling on emergency, radiation situation logging. Data of radiation control are used in the facility automated control to form blocks.

Conclusion

There has been developed a highly automated system for control, monitoring and data acquisition at the universal facility "Prometei", designed for studying the phenomenon of

tritium superpermeability through metal membranes, phenomena of tritium accumulation and transmission by metals and structural materials. A software-hardware complex of the automation system has been installed and adjusted, calibration jobs have been conducted. Trial experiments have been carried out with the MCS use at the “Prometei” facility.

The authors express their thanks to all specialists and employees of VNIIEF, who took part in development, manufacture and testing of the “Prometei” facility monitoring and control system.

References

1. S.K.Grishechkin, A.N.Golubkov, E.V.Gornostaev et al. Device for investigations of tritium retention in and permeation through metals and structural materials. Hydrogen Recycling at Plasma Facing Materials. Series II: Mathematical and Physical Chemistry. Vol. 1, p.339-348, 2000.
2. A.A.Yukhimchuk, V.A.Apasov, Yu.I.Vinogradov et al. RFNC-VNIIEF preprint, P.64-98. 1998.
3. A.Williams. Application of integrated chips.V.2, Moscow, Mir, 1987.